

## Bird diapers, helmet parachutes and tricycle lawnmowers: 10 strange and unusual patents

WHGC compiles 10 of the most absurd patent applications the firm has run across

By John F. O'Rourke, Patrick Soon, Trevor K. Roberts

\* This article first appeared in Inside Counsel Magazine on March 4, 2015: <http://bit.ly/1FaxYrV>

Over the years, the intellectual property group at WHGC has come across some very strange and unusual patents while conducting research, so we thought it might be fun to share with you those we found most interesting. The patents and the accompanying drawings below are real and have not been altered. We have also provided a link so that readers can click on the URLs and read the descriptions in more detail.

### 1. A bird diaper (U.S. Patent No. 5,934,226; Aug. 10, 1999)

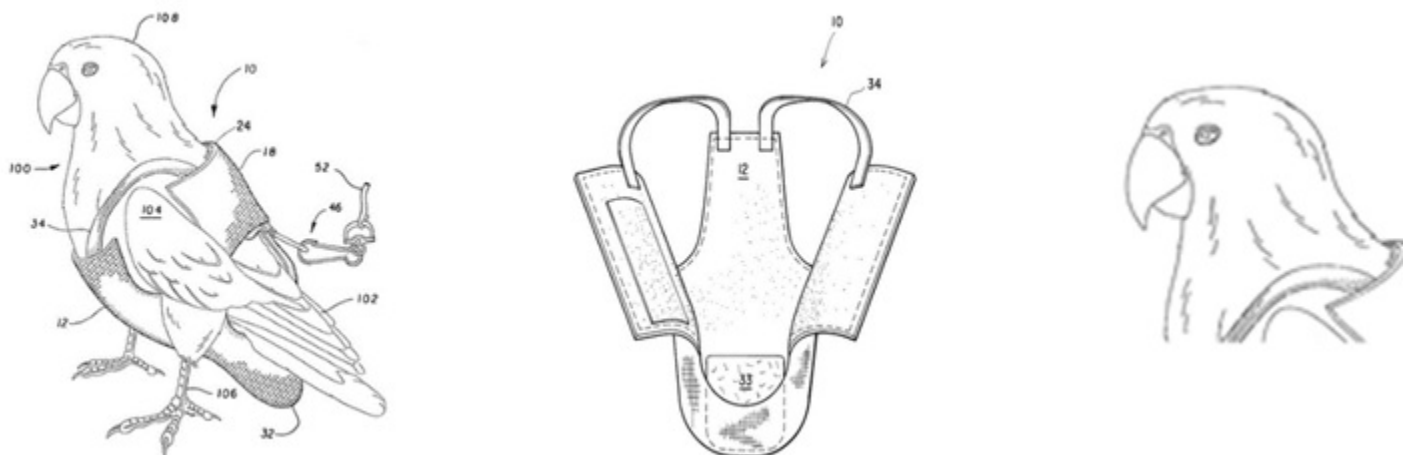

At first, we thought that a sanitary garment for a bird was a fine idea. The diaper is made of a soft, absorbent material, and the straps allow for the wings to move freely. You can even attach a leash to the tiny apparatus so that you can take your pet outside for a little exercise and fresh air. But then we thought about how difficult it could be to try to put such a device on real bird — a bird with a sharp beak and claws. The parrot in this illustration, for example, looks purely evil. With its lazy eye and mocking smile, it appears to be staring into your soul and thinking, “Do you really think you could put one of these things on me? Go ahead and try it. Make my day!”

### 2. A helium-filled sunshade (U.S. Patent No. 5,076,029; Dec. 31, 1991)

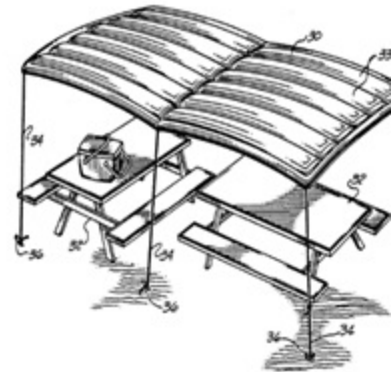
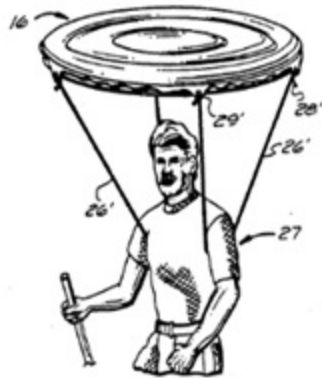

With this lighter-than-air sunshade, you will not need metal poles to hold a canvas in place. All you will need is some string to tether the balloon-like shade to the ground, or to loop over your shoulders while walking. And if you attach the device to an inner tube, you can even use the shade as an emergency flotation device if the tube goes flat. This could make a perfect Mother's Day gift! But make sure Mom does not mind hearing a few giggles behind her back, and make sure that she does not try to use this device on a windy day.

### 3. A growing doll (U.S. Patent No. 2,564,813; Aug. 21, 1951)

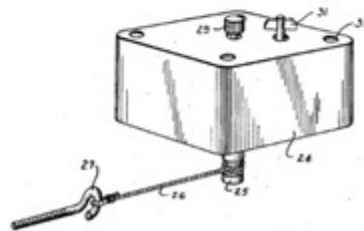
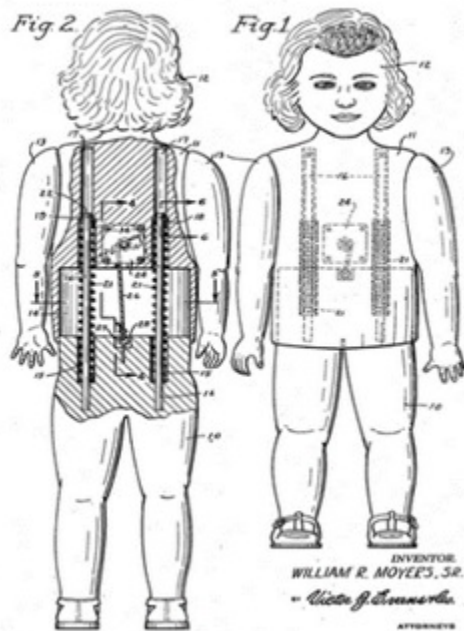

This is actually a very clever invention, especially for 1951. The doll is constructed with rods and movable parts, and when the mechanism is wound up, a string tightens and compresses the pieces together. But as the mechanism unwinds, the string slowly lets out and the parts separate under the tension of springs, simulating growth. Sounds fun and educational, right? But can you imagine a child cuddling this doll as she falls asleep, only to feel it move in the

middle of the night? And then waking to see that face staring at you, with its heavy-mascara eyes? A child would be scarred for life!

**4. A bird-powered blimp** (U.S. Patent No. 363,037; May 17, 1887)

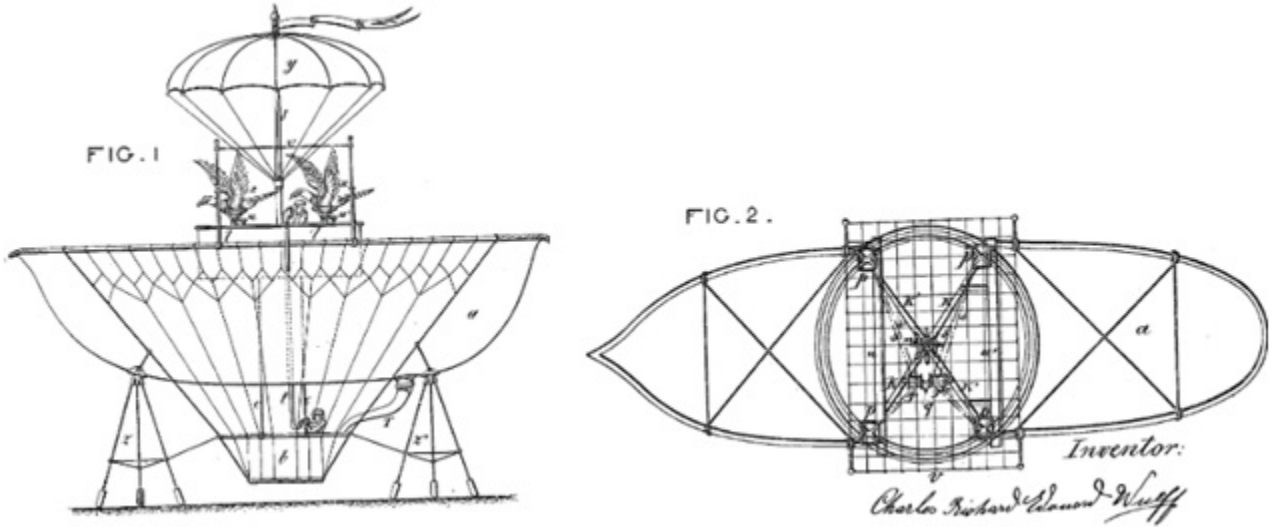

Believe it or not, the inventor does a good job of making this avian-powered aircraft sound viable in his description. He points out that a balloon actually does all the lifting, and that the harnessed eagles or condors only provide thrust. One navigates by simply pivoting the circular platform (center of fig. 2) to which the birds are attached toward the desired direction of flight. But before taking off, the pilot would be wise to first equip these bird propellers with the bird diapers discussed above — in size *XXL*!

**5. Human Body Sail** (U.S. Patent No. 5,713,603; Jan. 11, 1996)

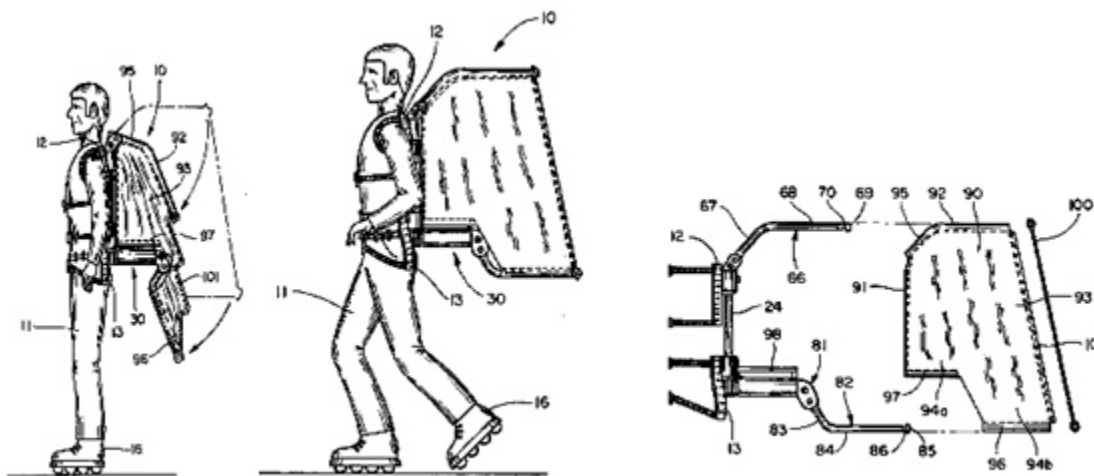

The idea behind this invention sounds simple enough: Just put on the retractable sail and a pair of roller blades and, with the first gust of wind, off you go! It is a very eco-friendly means of transportation. You'll feel like a wind-powered superhero skating down the street, at least until you hit that first pothole or crack in the sidewalk. Then you may just feel silly. Our suggestion is to first ask the inventor to demonstrate just how safe and controllable this contraption really is before you strap it on. We note that the man in the illustration is not wearing any pads — but he does appear to have helmet hair.

#### 6. **Tricycle Lawnmower** (U.S. Patent No. 4,455,816; June 26, 1984)

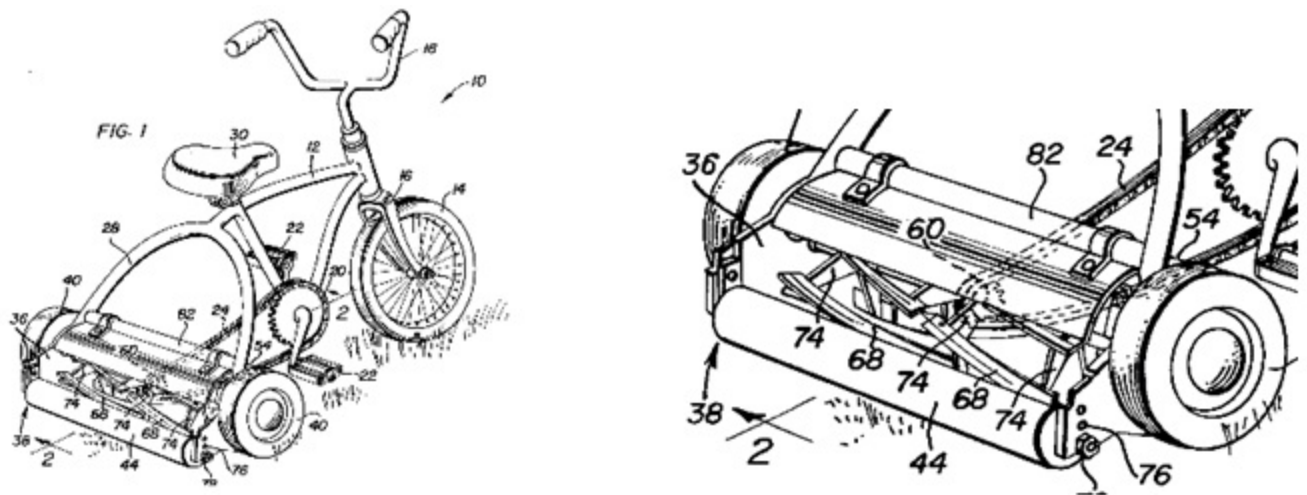

Trying to think of a good gift for your young nephew or niece for Easter? How about this handy-dandy, pedal-powered lawnmower? After all, if the kids are going to be riding their scooters and cycles around the yard anyway, why not put all that energy to use? With this trike, they can simultaneously cut the grass and gallivant with their friends. Besides, what's the worst thing that could happen? It's just some swirling, sharp blades attached to a child's plaything.

#### 7. **Marine mammal communication device** (U.S. Patent No. 5,392,735; Feb. 28, 1995)

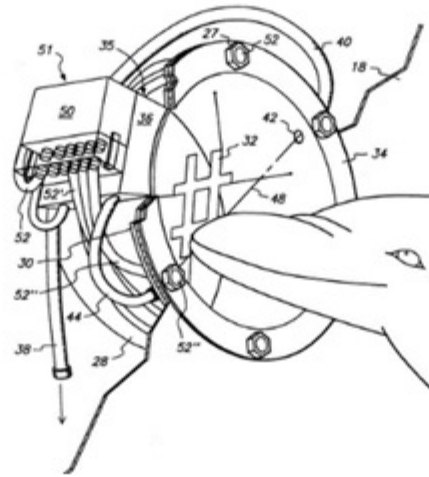
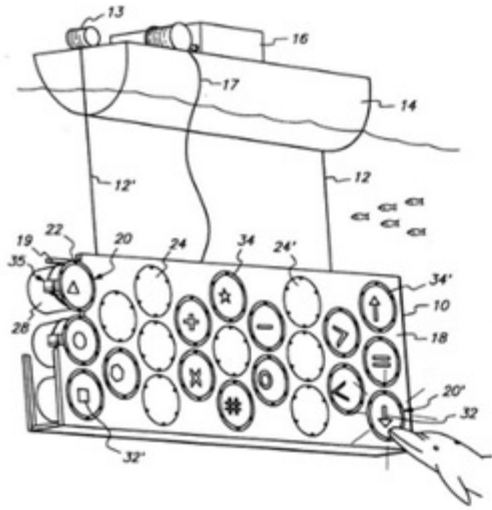

This oversized submersible keyboard is intended to allow sea animals “to communicate with humans and with each other.” Now people can text porpoises and ask them questions like, “Where can we ride the best waves?” or, “Don’t you ever get tired of eating fish?” But allowing marine life to use such a device to communicate with each other could be dangerous. Dolphins could begin spending too much time using this invention to gossip about other aquatic life, and they could begin neglecting their dolphin-duties. Undersea texting could also cause mates to split apart. For example, a whale could be asked by his mate, “Do you think this plankton makes me look fat?” To which the male might respond, “Well, you are a whale...” Perhaps the device should include a message recall function.

**8. Three-legged Pantyhose** (U.S. Patent No. 5713081; Nov. 18, 1996)

**FIG. 1**

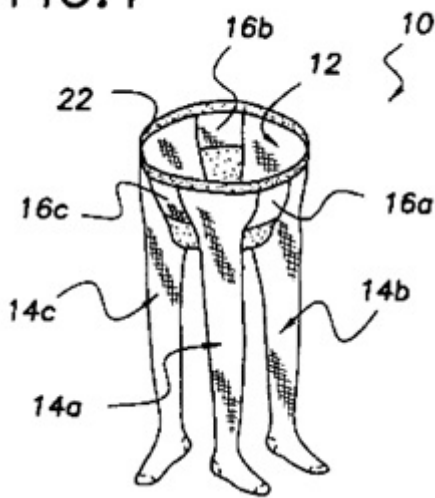

**FIG. 2**

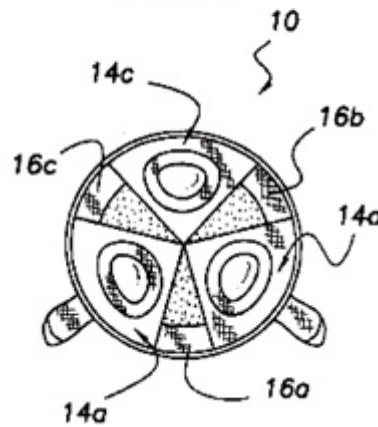

No, this is not underwear for people with three legs. This clever invention is intended to double the life of a woman’s hosiery. One of the legs is a spare that tucks into a pocket until needed.



That way, if the wearer has a run in a stocking, she will have a backup. She can just take out the good stocking, and tuck the damaged one away. This invention could really come in handy in an emergency, say right before a hearing. But can you imagine the reaction at the laundromat if the customers there saw three legged-pantyhose swirling around in one of the dryers?

**9. Doggie-ear Protectors (U.S. Patent No. 4233942; Nov. 18, 1980)**

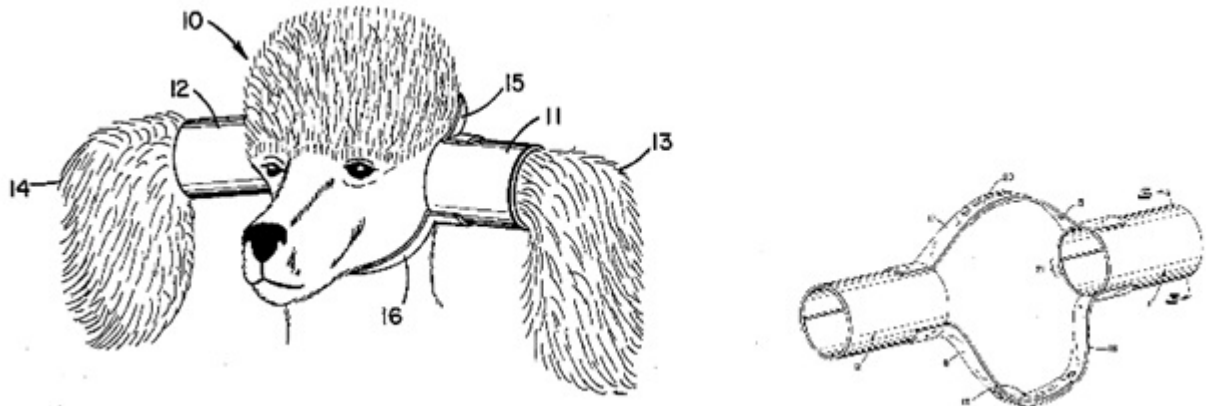

Do your Poodle's ears get messy every time she eats? Does your Basset Hound's ears get wet every time he gets a drink? Well, fret no more. With this invention, dogs will now be able to keep their long ears out of their bowls. Yes, they may look like toilet paper inserts, and yes the dog in the drawing looks extremely embarrassed, but these devices could be big trouble-savers. Have you ever seen what a Cocker Spaniel's ears look like after eating left-over spaghetti? It's a horrifying sight.

**10. Parachute Fire Escape (U.S. Patent No. 221,855; Nov. 18, 1879)**

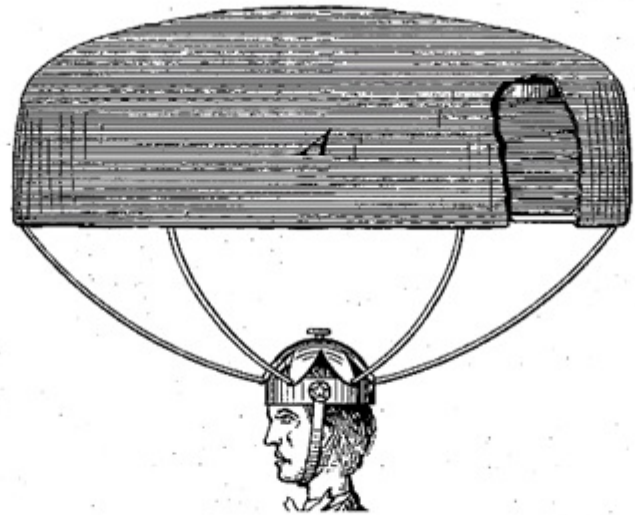

This drawing probably made us laugh harder than any of the others. The lines used to shade the man's face make it look like he crying, and the open mouth makes it look like he is screaming in terror – and he should be! Just imagine what would happen if this device was really able to stop a body in freefall, and allow it to descend at a survivable rate of speed. Upon deployment, such a head-mounted parachute would probably decapitate you (or at least leave you with a very long neck!). Fortunately, if the helmet-chute fails to slow your descent, there is a backup. No, not a reserve chute, but a pair of thickly padded shoes. These, it is hoped, will soften your impact upon landing enough that you can walk away from the incident unharmed. If only there were YouTube videos of them testing this invention back in 1879!

#### **CONTRIBUTING AUTHOR**



**John F. O'Rourke**

John F. O'Rourke is a registered patent attorney and inventor at WHGC, P.L.C. He has nearly 40 years of overall experience in the applied sciences. He counsels and represents clients in matters concerning technology and intellectual property law. Mr. O'Rourke has prepared several hundred original U.S. patent applications across a broad spectrum of technical disciplines. [JohnORourke@WHGCLaw.com](mailto:JohnORourke@WHGCLaw.com)

#### **CONTRIBUTING AUTHOR**



**Patrick Soon**

Patrick Soon is an attorney at WHGC, P.L.C. whose practice focuses on intellectual property. Outside of his work at WHGC, Mr. Soon volunteers for the American Bar Association where he works as an editor and multimedia chair for the Technology for the Litigator Committee within the ABA Section of Litigation. [PatrickSoon@WHGCLaw.com](mailto:PatrickSoon@WHGCLaw.com)

#### **CONTRIBUTING AUTHOR**



**Trevor K. Roberts**

Trevor K. Roberts is Of Counsel at WHGC, P.L.C. Mr. Roberts studied Mandarin at Taiwan Normal University and worked in Taiwan for almost ten years as a magazine editor and television host. In addition to his work for WHGC, Mr. Roberts is an adjunct professor at Trinity Law School and California Baptist University.